



3-PC. SCREWED END BALL VALVE

2013



FEATURES

- Full port, 1/4"~4" (DN8~DN100)
 - W.P. : 1000 WOG (PN63)
 - W.T. : -20°C~200°C (-4°F~392°F)
 - Investment casting
 - Blow-out proof stem
 - Anti-static device (option)
 - Locking device
- Thread type : ASME B1.20.1 (NPT)
DIN2999 & BS21
ISO7/1 & EN10226

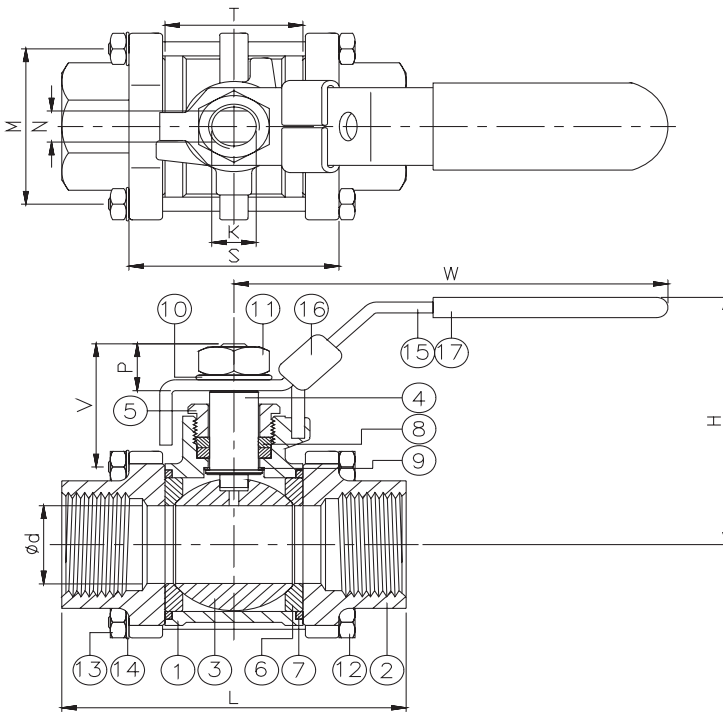

ITEM	PARTS	MATERIAL	
1	BODY	ASTM A351-CF8M	ASTM A216-WCB
2	CAP		
3	BALL	ASTM A351-CF8M	
4	STEM	ASTM A276-316	
5	GLAND NUT	AISI 304	
6	SEAT	RTFE / PTFE / CTFE	
7	SEAL		
8	PACKING	PTFE	
9	THRUST WASHER		
10	SPRING WASHER		
11	STEM NUT		
12	BOLT		
13	NUT	AISI 304	
14	SPRING WASHER		
15	HANDLE		
16	LOCKING DEVICE		
17	HANDLE SLEEVE	PVC	

DN	d	L	H	W	S	T	N	P	K	Weight (kg)
8	11.6	64.5	56	102	35.5	21.5	5	9.5	5/16"UNC	0.4
10	12.7	64.5	56	102	35.5	21.5	5	9.5	5/16"UNC	0.4
15	15	66	57	102	38	24	5	10.5	5/16"UNC	0.5
20	20	83.4	66	120.5	43	28	6.5	13.5	3/8"UNC	0.7
25	25	95	76	158.5	54	35	8	15.5	7/16"UNC	1.1
32	32	111.2	81	158.5	65	45	8	15.5	7/16"UNC	1.7
40	38	130	98	188	75	55	9	17.5	1/2"UNC	2.4
50	50	151	106	188	88	66	9	17.5	1/2"UNC	3.6
65	65	184	138	245	114	86	12	33	3/4"UNC	8.9
80	80	209	154	290	132	100	12	33	3/4"UNC	14.3
100	100	234.4	178	320	158	125	16	42	1"UNC	23.4

unit:mm

NPS	d	L	H	W	S	T	N	P	K	Weight (lb)
1/4"	0.46	2.54	2.2	4.02	1.4	0.85	0.2	0.37	5/16"UNC	0.9
3/8"	0.5	2.54	2.2	4.02	1.4	0.85	0.2	0.37	5/16"UNC	0.9
1/2"	0.59	2.6	2.24	4.02	1.5	0.94	0.2	0.41	5/16"UNC	1.1
3/4"	0.79	3.28	2.6	4.74	1.69	1.1	0.26	0.53	3/8"UNC	1.5
1"	0.98	3.74	2.99	6.24	2.13	1.38	0.31	0.61	7/16"UNC	2.4
1-1/4"	1.26	4.38	3.19	6.24	2.56	1.77	0.31	0.61	7/16"UNC	3.7
1-1/2"	1.5	5.12	3.86	7.4	2.95	2.17	0.35	0.69	1/2"UNC	5.3
2"	1.97	5.94	4.17	7.4	3.46	2.6	0.35	0.69	1/2"UNC	7.9
2-1/2"	2.56	7.24	5.43	9.65	4.49	3.39	0.47	1.3	3/4"UNC	19.6
3"	3.15	8.23	6.06	11.42	5.2	3.94	0.47	1.3	3/4"UNC	31.5
4"	3.94	9.23	7.01	12.6	6.22	4.92	0.63	1.65	1"UNC	51.6

unit:in



8F., No.201, Sec. 2, Tiding Blvd., Neihu District, Taipei City 114, Taiwan R.O.C.
TEL : +886-2-2658-5800 FAX : +886-2-2658-2266 / 2799-7766

[Http://www.haitima.com.tw](http://www.haitima.com.tw)
E-mail : haitima@seed.net.tw